

Part Number : FK-FA1420

Product Name : ONE CHANNEL 12V RELAY MODULE

This is the experimental module for a relay controller as the fundamental controlling programming. It is adaptable or is able to upgrade to another forms of circuit such as Electric Appliances Timer.

Specification

- 1.Power Supply direct from Microcontroller Board. (On the Relay circuit, it can be connected with internal power supply at 12VDC [from Arduino Board] or with external power supply.)
- 2.The circuit can be used with Microcontroller Board such as Arduino UNO R3.
3. The circuit is composed of 1 set of Relay circuit.
- 4.PCB dimension : 2.32"x0.91"

Circuit Function

The circuit is composed of 1) Opto-Transistor which is a driver for the relay circuit. To control the relay, Opto-Transistor works through CH pin of FK1420. 2) Relay circuit 12VDC which is supplied by two options: **A.** in case of supplying from Arduino Board (connect adaptor with the direct current at 12VDC to Arduino Board), put jumpers in J+ point and JG. Connect the pin+ of FK1420 with Vin point of Arduino board, connect G pin with GND point of Arduino board. **B.** In case of supplying the direct current at 12VDC from external power supply through connecting FK1420, remove jumpers from J+ point and JG point and supply the direct current at 12VDC from the external power supply to 12V point near the relay.

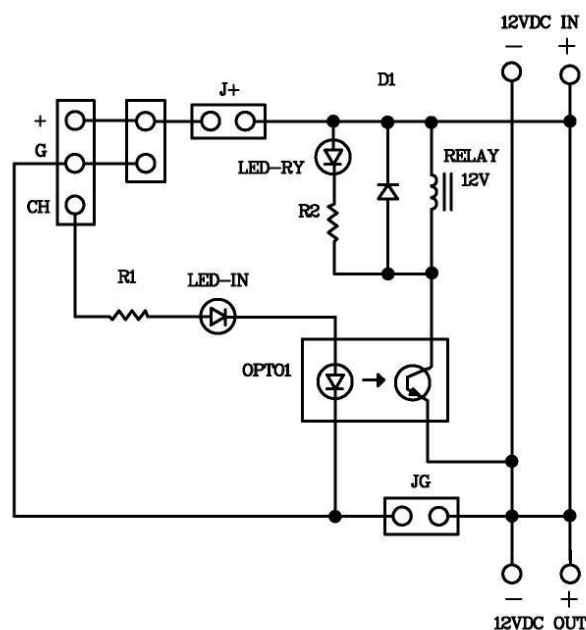

Figure 1. Circuit Diagram of FK1420

Circuit Assembling

According to Figure 2, the easy assembling should be started with putting the smallest part on the circuit which is resistor. Caution, all parts must be on the right electrodes such as LED. Please see Figure 3 for putting parts on electrodes. On the soldering, use a soldering iron max. 40 watts and tin/lead at 60/40 with flux. After assembling and soldering, re-check the positions of each part. In case some parts are on the wrong positions, use solder suction or solder wick to correct the positioning of those parts.

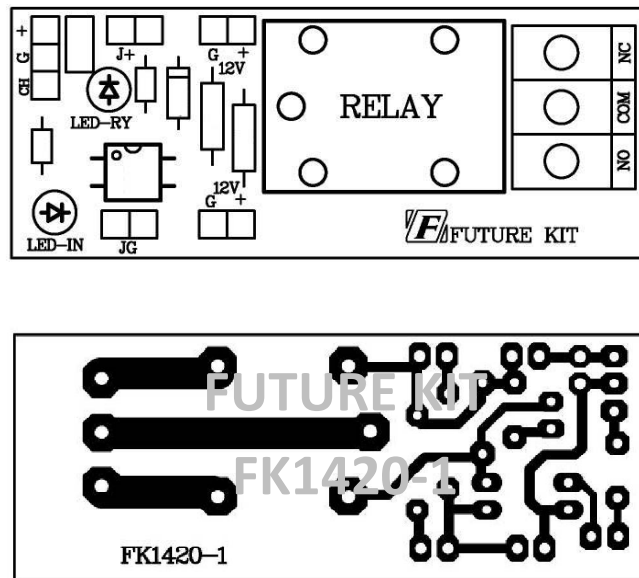

Figure 2. The positions for assembling and PCB copper line.

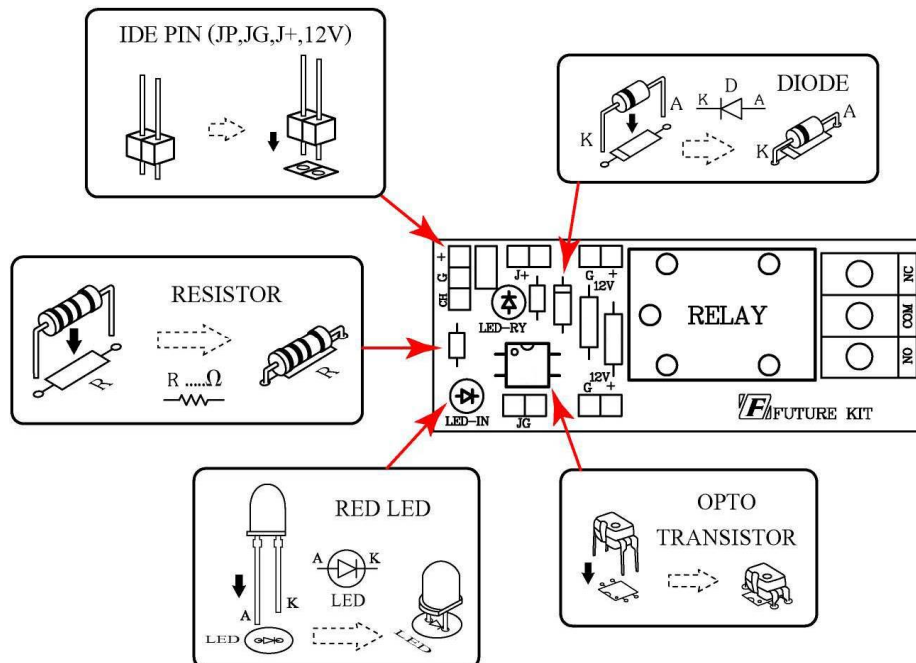

Figure 3. Positioning the parts on PCB

Programming instrument for the experimental board

1.FK-FA1420 ONE CHANNEL 12V RELAY MODULE	1	set
2. 12VDC 500mA. Power Adaptor	1	Piece
3. Microcontroller Board ex. Arduino UNO R3	1	set
4. USB Cable	1	Piece
5. Computer Set	1	Set
6. Arduino Software	1	Piece

Testing Arduino UNO R3 Board

1.Connect USB cable with USB port of computer and USB port of Arduino UNO R3 Board.

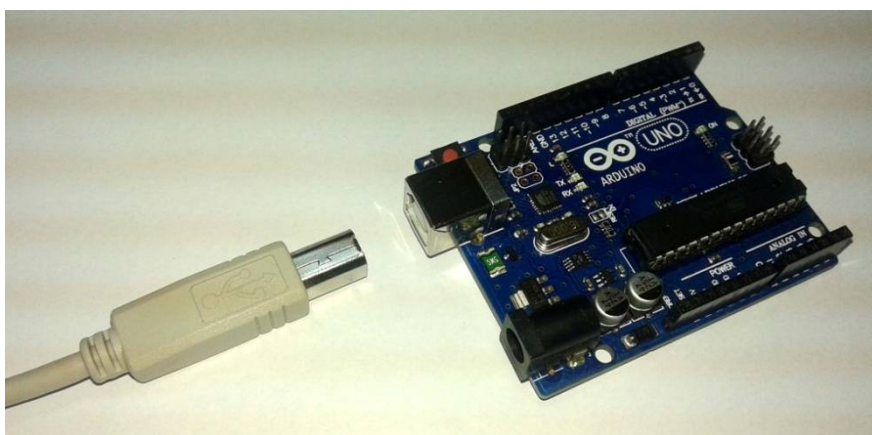

Figure 4. Connecting USB cable with USB port of Arduino Board

2. Open Arduino program by double-click on Arduino icon. Go to the menu bar, click on File and choose Open. Go to "EX" folder, open "TEST" folder and click on "Test" file.

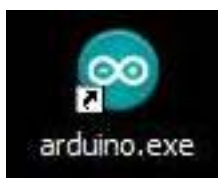

Figure 5. Opening Arduino program

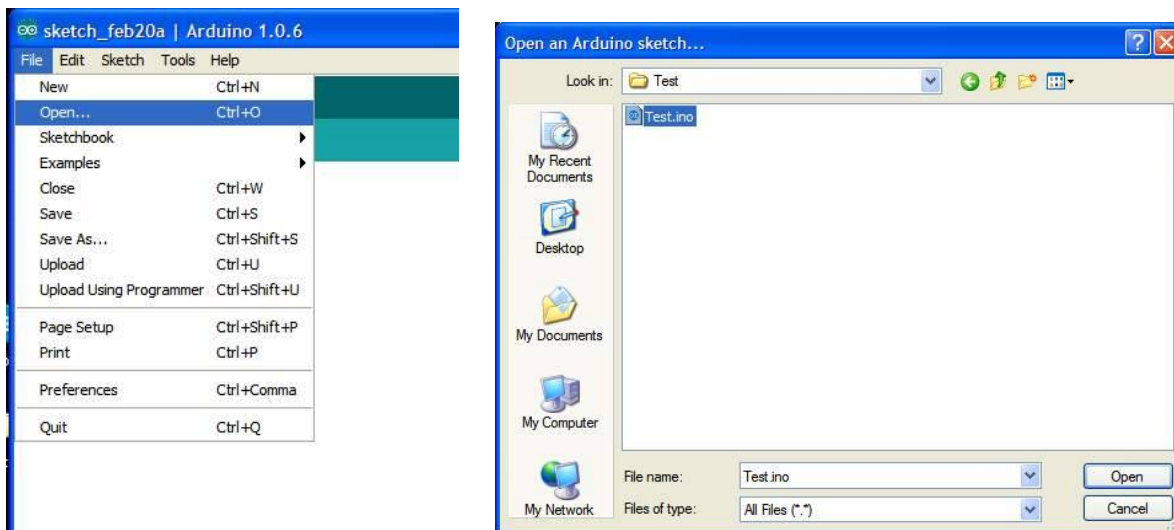

Figure 6. TEST Program

3.Download TEST program to Arduino Board.



Figure 7. Downloading TEST program

4.After downloading, the LED L on Arduino Board will blink which means Arduino board is working.



Figure 8. The position of LED L on Arduino Board circuit

The details of TEST program, Flashing Light Program, Arduino UNO R3 experiment.

```
void setup() {  
  
  pinMode(13, OUTPUT);      // Set the pin 13 is OUTPUT pin.  
  
}  
  
void loop() {  
  
  digitalWrite(13, HIGH);   // LED at the pin 13 is light-on.  
  
  delay(1000);              // delay time 1 second  
  
  digitalWrite(13, LOW);   // LED at the pin 13 is light-off.  
  
  delay(1000);              // delay time 1 second  
  
}
```

The method to connect the circuit with Arduino UNO R3 board

Connect FK1420 board with Arduino UNO R3 board by following Figure 9. With CH point is connect to pin 13, + point is connect to Vin point and G point is connect to GND.

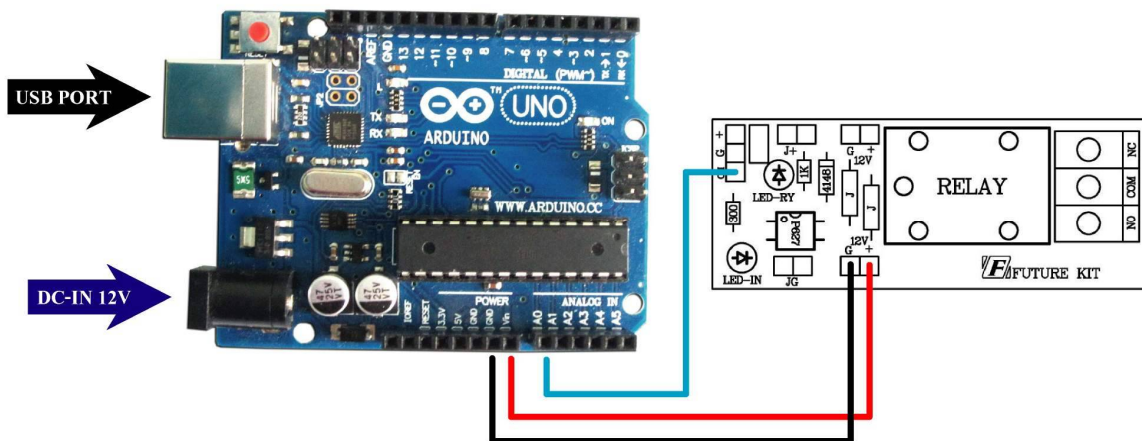

Figure 9. Connecting FK1420 board with Arduino UNO R3 board

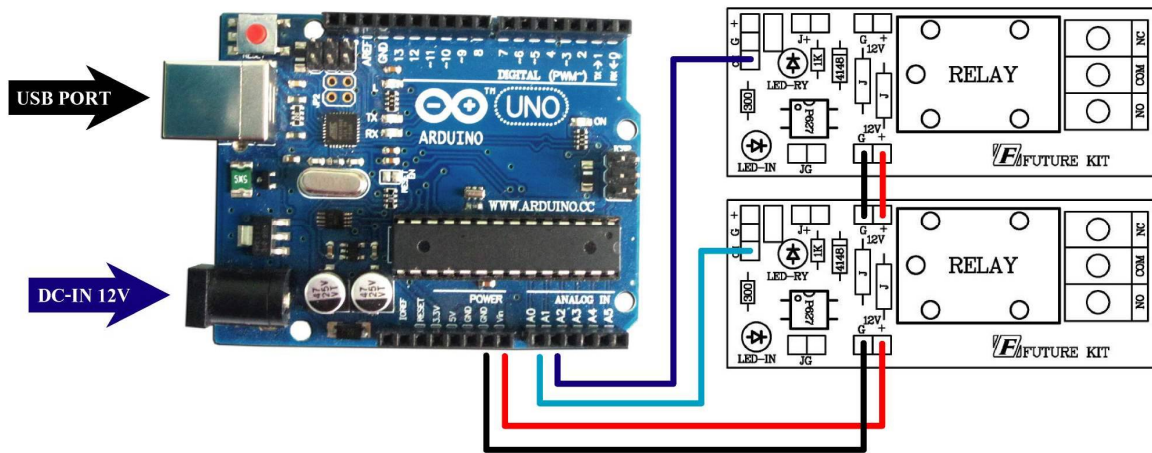

Figure 10. Multi-connection FK1420 board with Arduino UNO R3 board

Programming

1. Connect Arduino UNO R3 board with experimental board by following the instruction of the method to connect the circuit with Arduino UNO R3 board. And then jumping the jumper at J+ point and JG point and connect the power adaptor to DC-IN on Arduino board

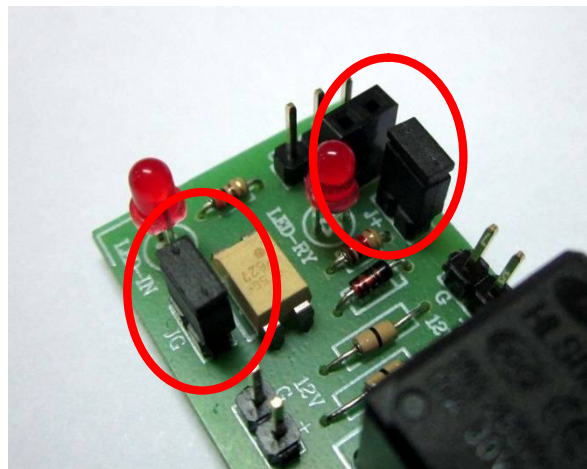

Figure 11. Jumping the jumper at J+ point and G point

2. Connect the USB cable with USB port of computer and USB port of Arduino UNO R3 board.



Figure 12. Wiring the USB cable

3. Double-click on Arduino icon to open Arduino program. Go to "File" in menu bar and choose "Open". Click on folder "Ex", choose folder "FK1420", choose folder "LAB1420-1" and click on file "LAB1420-1".

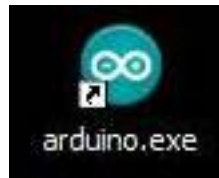

Figure 13. Opening Arduino Program

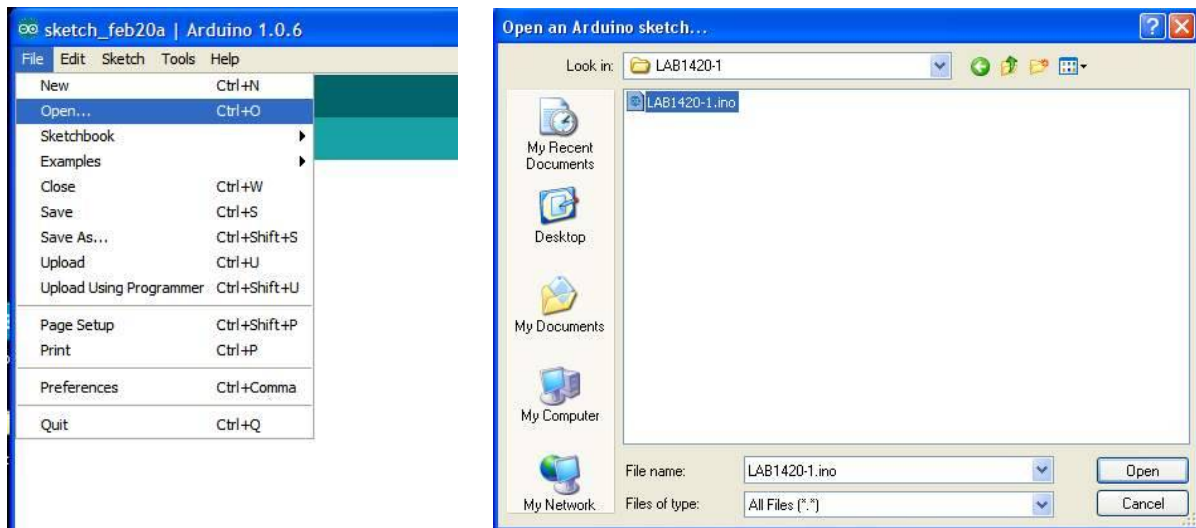

Figure 14. LAB1420-1 program

4. Download LAB1420-1 program to Arduino board. After downloading, there will be the sound of relay is working and stop working alternately. Also LED-IN and LED-RY will be light-on and light-off alternately which means the relay circuit is working.

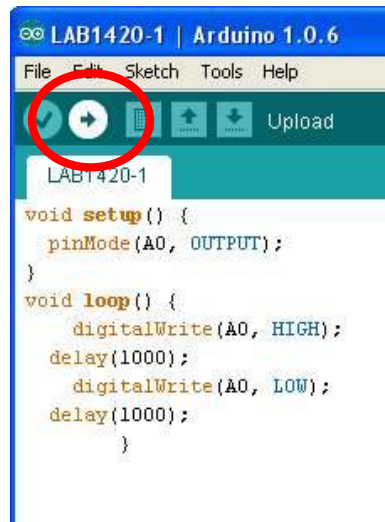

Figure 15. Downloading LAB1420-1 program

5. Insert the jumper at JP2 point in the position of A. Download LAB1420-2 program to Arduino board. After downloading, test the circuit by clapping hands or raise any sounds to the microphone, the result is the LED will be light-on for a while, then light-off.

The details of LAB1420-1 RELAY TEST program

```
void setup() {  
    pinMode(13, OUTPUT);    // Set the pin 13 is OUTPUT pin.  
}  
  
void loop() {  
    digitalWrite(13, HIGH);    // RELAY at the pin 13 is working.  
    delay(1000);              // delay time 1 second  
    digitalWrite(13, LOW);    // RELAY at the pin 13 is stop working.  
    delay(1000);              // delay time 1 second  
}
```

Function of LAB1420-1 program

The program will set pin 13 as OUTPUT pin. The relay at pin 13 will be light-on at 1 second and light-off at 1 second, then the program will start repeating the relay.

Remark: In case we want LED ON/OFF to blink frequency, reduce the value in the parentheses by commanding “delay”. The unit of the digit is millisecond.